

PARTS LIST					
ITEM	QTY	PART NO.	PART DESCRIPTION	UNIT WT.	NET WT.
1	1	CSRT2-8108	CSRT SERIES™ 2 PIPE SLOPE MOUNT 8' FACE X 10' MAST X 8' DEPTH	801.70	801.70
2	1	CSRT-RRU2-410	CONSTRUCTOR SERIES 4' X 10' 2 LAYER RRU RACK	146.39	146.39
TOTAL WT. #				948.09	

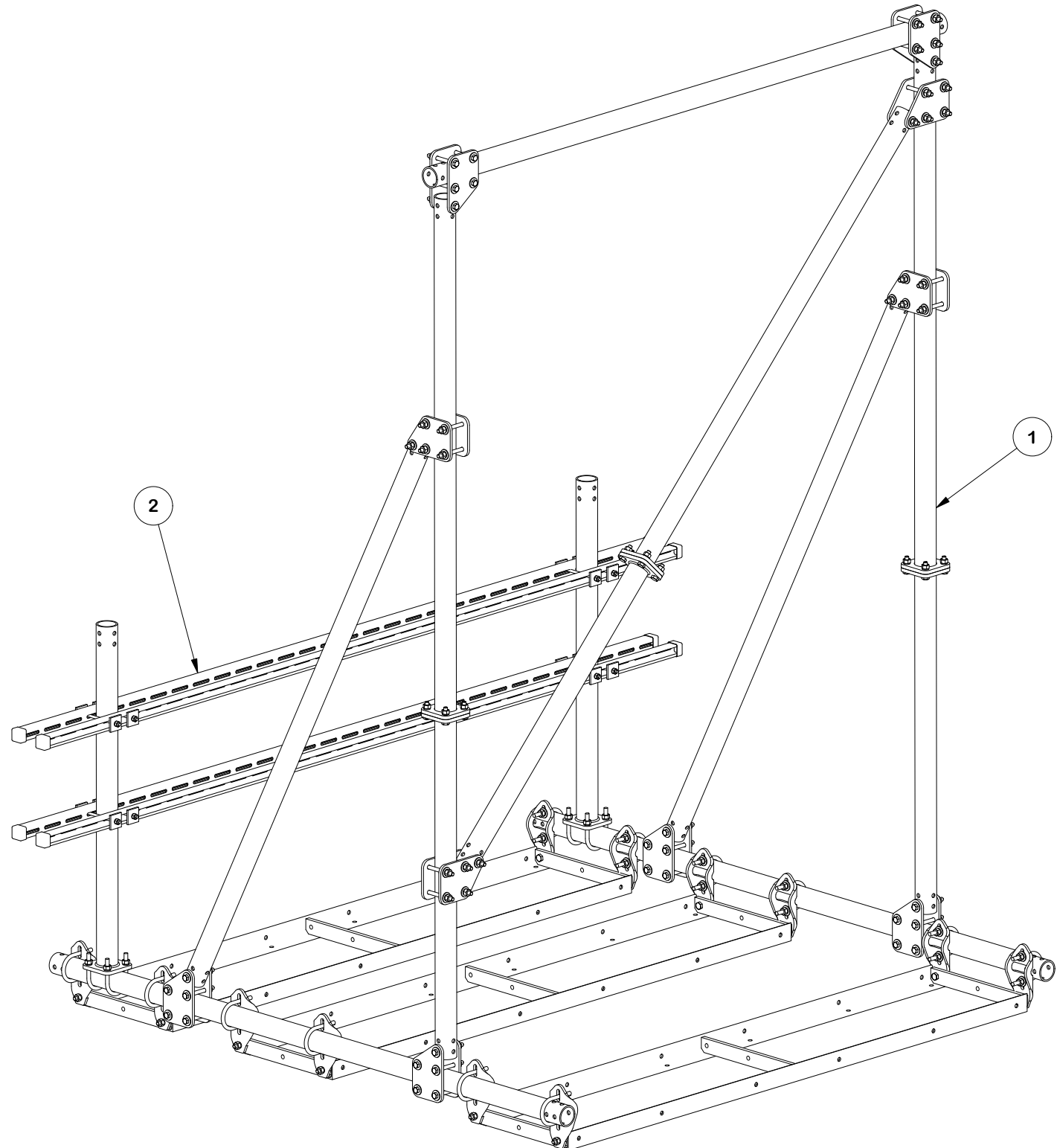

FINISH:
HOT DIP GALVANIZED.

TOLERANCE NOTES

TOLERANCES ON DIMENSIONS, UNLESS OTHERWISE NOTED ARE:
 SAWED, SHEARED AND GAS CUT EDGES ($\pm 0.030"$)
 DRILLED AND GAS CUT HOLES ($\pm 0.030"$) - NO CONING OF HOLES
 LASER CUT EDGES AND HOLES ($\pm 0.010"$) - NO CONING OF HOLES
 BENDS AND ANGLES ARE $\pm 1/2$ DEGREE
 ALL OTHER MACHINING ($\pm 0.030"$)
 ALL OTHER ASSEMBLY ($\pm 0.060"$)

PATENT INFORMATION: WWW.SITEPRO1.COM/PATENTS

PROPRIETARY NOTE:
 THE DATA AND TECHNIQUES CONTAINED IN THIS DRAWING ARE PROPRIETARY INFORMATION OF VALMONT INDUSTRIES AND CONSIDERED A TRADE SECRET. ANY USE OR DISCLOSURE WITHOUT THE CONSENT OF VALMONT INDUSTRIES IS STRICTLY PROHIBITED.

DESCRIPTION
**CSRT SERIES™ 2 PIPE SLOPE MOUNT
 8' FACE X 10' MAST X 8' DEPTH
 W/ RRU RACK**

CPD NO. SP1	DRAWN BY SDR 10/8/2025	ENG. APPROVAL 11/11/2025
CLASS 87	SUB 02	DRAWING USAGE CUSTOMER
CHECKED BY ADB 11/11/2025		



A valmont COMPANY

Engineering Support Team:
sp1engineering@valmont.com

PART NO. CSRT2-8108-R	PAGE 1 OF 7
DWG. NO. CSRT2-8108-R	

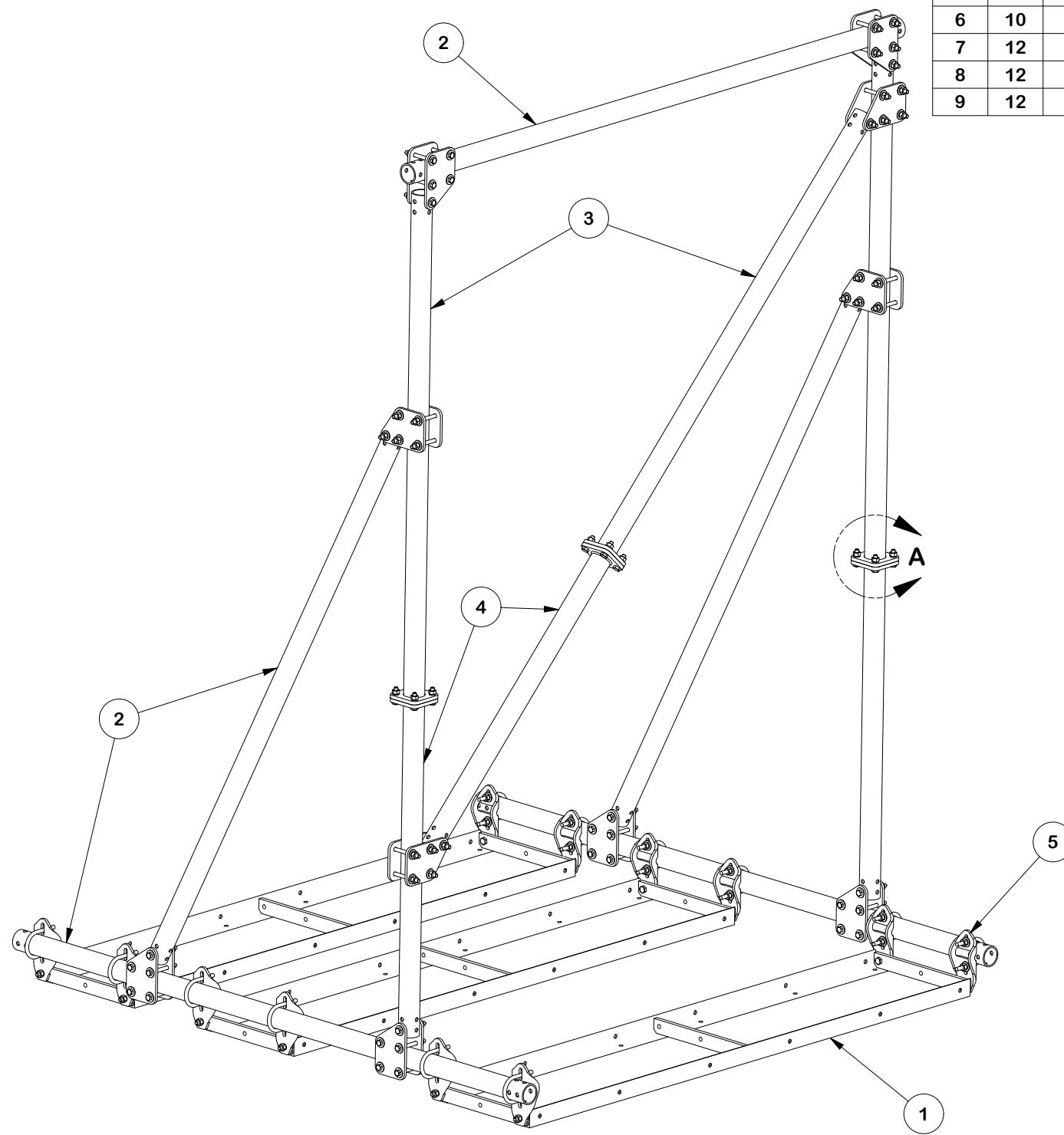

PARTS LIST								
ITEM	QTY	PART NO.	BOX NO.	PART DESCRIPTION	LENGTH	UNIT WT.	NET WT.	
1	3	X-232696		BALLAST TRAY WELDMENT - SITE PRO 1		66.60	199.79	
2	5	X-CSRT-P3096		2-7/8" DIA. PIPE X 96" LONG	96 in	48.99	244.97	
3	3	X-CSRT-3072FW		CSRT FLANGE PIPE WELDMENT 2-7/8" X 72"		39.16	117.47	
4	3	X-CSRT-3048FW		CSRT FLANGE PIPE WELDMENT 2-7/8" X 48"		26.85	80.54	
5	12	CSRT-PCB	P-CSRT-PCB	CSRT PIPE CLAMP BRACKET KIT		4.25	50.95	
6	10	CSRT-GP30	P-CSRT-GP30	CSRT GUSSET PLATE KIT		10.49	104.85	
7	12	G1202		1/2" x 2" HDG HEX BOLT GR5	2 in	0.18	2.11	
8	12	G12LW		1/2" HDG LOCKWASHER	1/8 in	0.01	0.17	
9	12	G12NUT		1/2" HDG HEAVY 2H HEX NUT	7/8 in	0.07	0.86	
TOTAL WT. #							801.70	

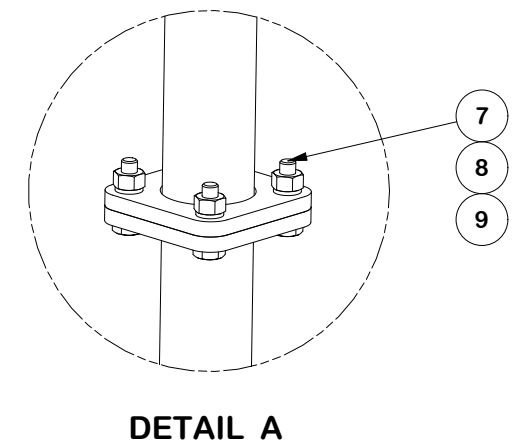

FINISH:
HOT DIP GALVANIZED.

					TOLERANCE NOTES TOLERANCES ON DIMENSIONS, UNLESS OTHERWISE NOTED ARE: SAWED, SHEARED AND GAS CUT EDGES ($\pm 0.030"$) DRILLED AND GAS CUT HOLES ($\pm 0.030"$) - NO CONING OF HOLES LASER CUT EDGES AND HOLES ($\pm 0.010"$) - NO CONING OF HOLES BENDS AND ANGLES ARE $\pm 1/2$ DEGREE ALL OTHER MACHINING ($\pm 0.030"$) ALL OTHER ASSEMBLY ($\pm 0.060"$)			DESCRIPTION CSRT SERIES™ 2 PIPE SLOPE MOUNT 8' FACE X 10' MAST X 8' DEPTH W/ RRU RACK			 Engineering Support Team: sp1engineering@valmont.com A valmont COMPANY						
REVISION HISTORY					PATENT INFORMATION: WWW.SITEPRO1.COM/PATENTS			CPD NO. SP1		DRAWN BY SDR 10/8/2025		ENG. APPROVAL 11/11/2025		PART NO. CSRT2-8108			
A REVISED DIAGONAL SUPPORT					PROPRIETARY NOTE: THE DATA AND TECHNIQUES CONTAINED IN THIS DRAWING ARE PROPRIETARY INFORMATION OF VALMONT INDUSTRIES AND CONSIDERED A TRADE SECRET. ANY USE OR DISCLOSURE WITHOUT THE CONSENT OF VALMONT INDUSTRIES IS STRICTLY PROHIBITED.			CLASS 87		SUB 02		DRAWING USAGE CUSTOMER		CHECKED BY ADB 11/11/2025		DWG. NO. CSRT2-8108-R	

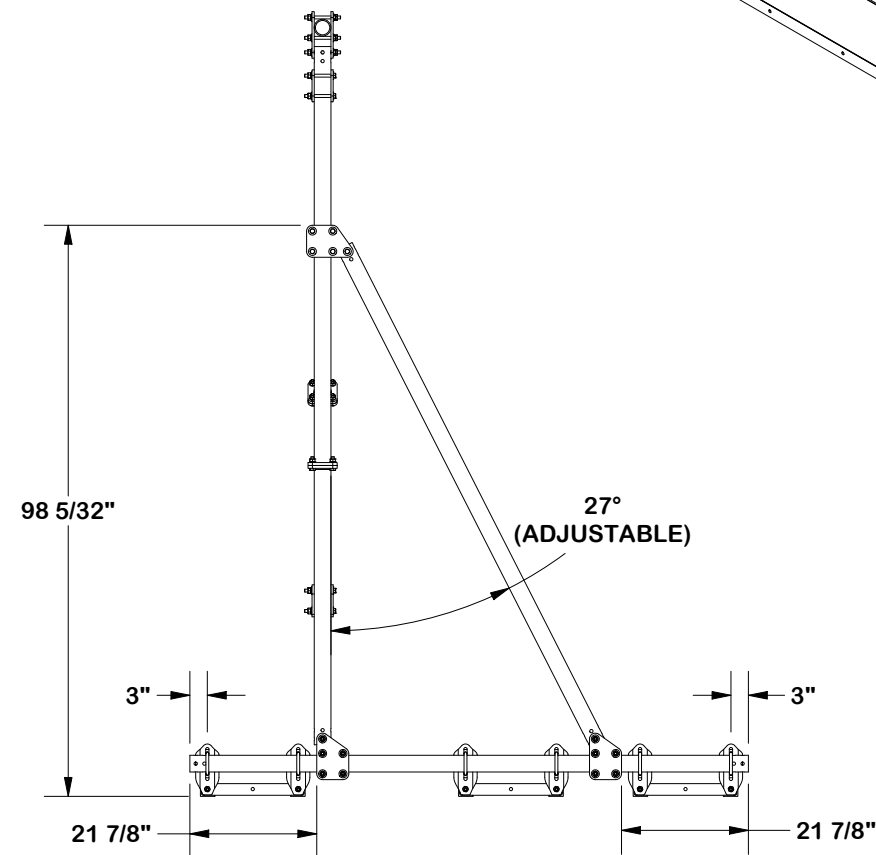
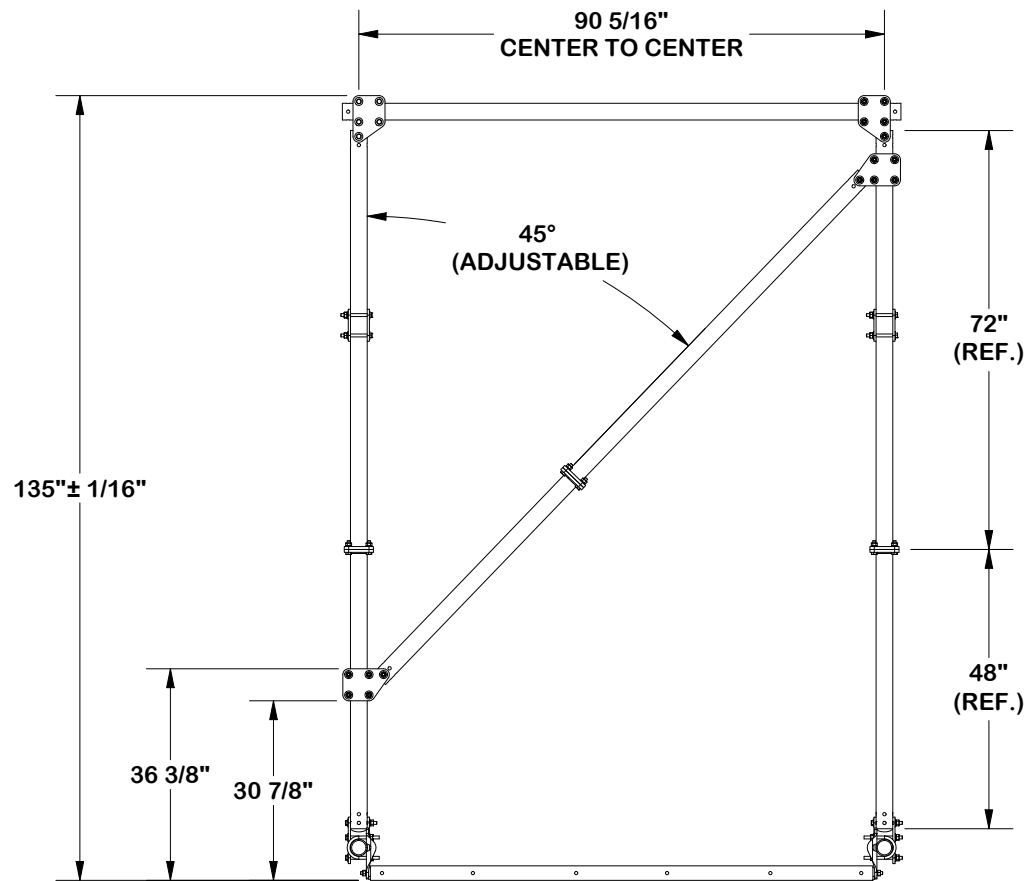
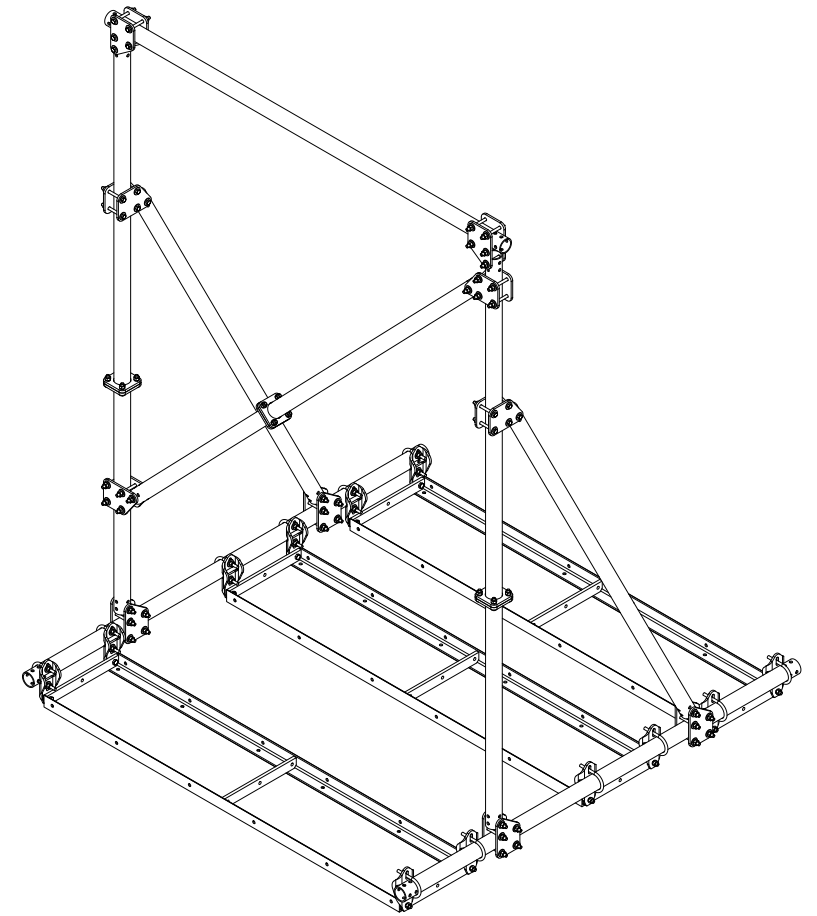
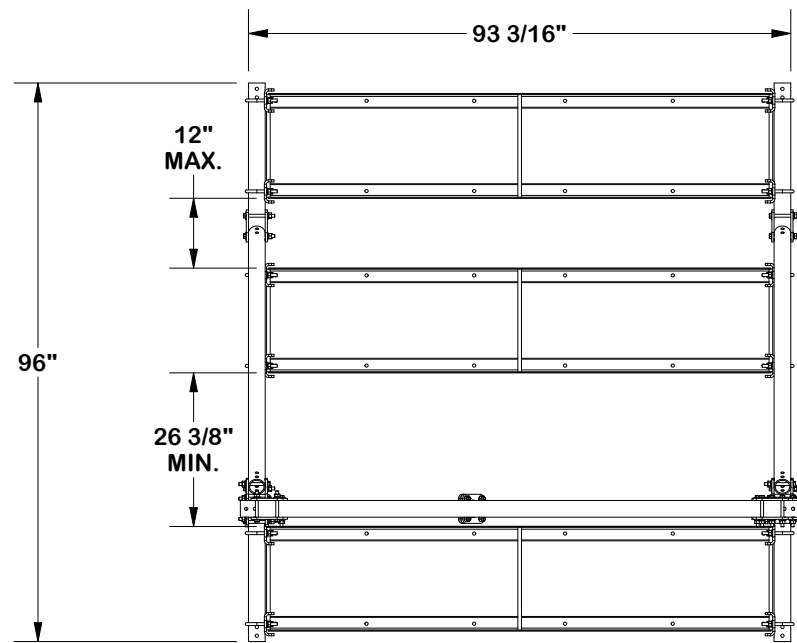

TOLERANCE NOTES

TOLERANCES ON DIMENSIONS, UNLESS OTHERWISE NOTED ARE:
 SAWED, SHEARED AND GAS CUT EDGES ($\pm 0.030"$)
 DRILLED AND GAS CUT HOLES ($\pm 0.030"$) - NO CONING OF HOLES
 LASER CUT EDGES AND HOLES ($\pm 0.010"$) - NO CONING OF HOLES
 BENDS AND ANGLES ARE $\pm 1/2$ DEGREE
 ALL OTHER MACHINING ($\pm 0.030"$)
 ALL OTHER ASSEMBLY ($\pm 0.060"$)

PATENT INFORMATION: WWW.SITEPRO1.COM/PATENTS

PROPRIETARY NOTE:
 THE DATA AND TECHNIQUES CONTAINED IN THIS DRAWING ARE PROPRIETARY INFORMATION OF VALMONT INDUSTRIES AND CONSIDERED A TRADE SECRET. ANY USE OR DISCLOSURE WITHOUT THE CONSENT OF VALMONT INDUSTRIES IS STRICTLY PROHIBITED.

DESCRIPTION
CSRT SERIES™ 2 PIPE SLOPE MOUNT
8' FACE X 10' MAST X 8' DEPTH
W/ RRU RACK

CPD NO. SP1	DRAWN BY SDR 10/8/2025	ENG. APPROVAL 11/11/2025
CLASS 87	SUB 02	DRAWING USAGE CUSTOMER
		CHECKED BY ADB 11/11/2025



Engineering Support Team:
 sp1engineering@valmont.com

PART NO. CSRT2-8108
DWG. NO. CSRT2-8108-R

CSRT™ SLOPE REFERENCE

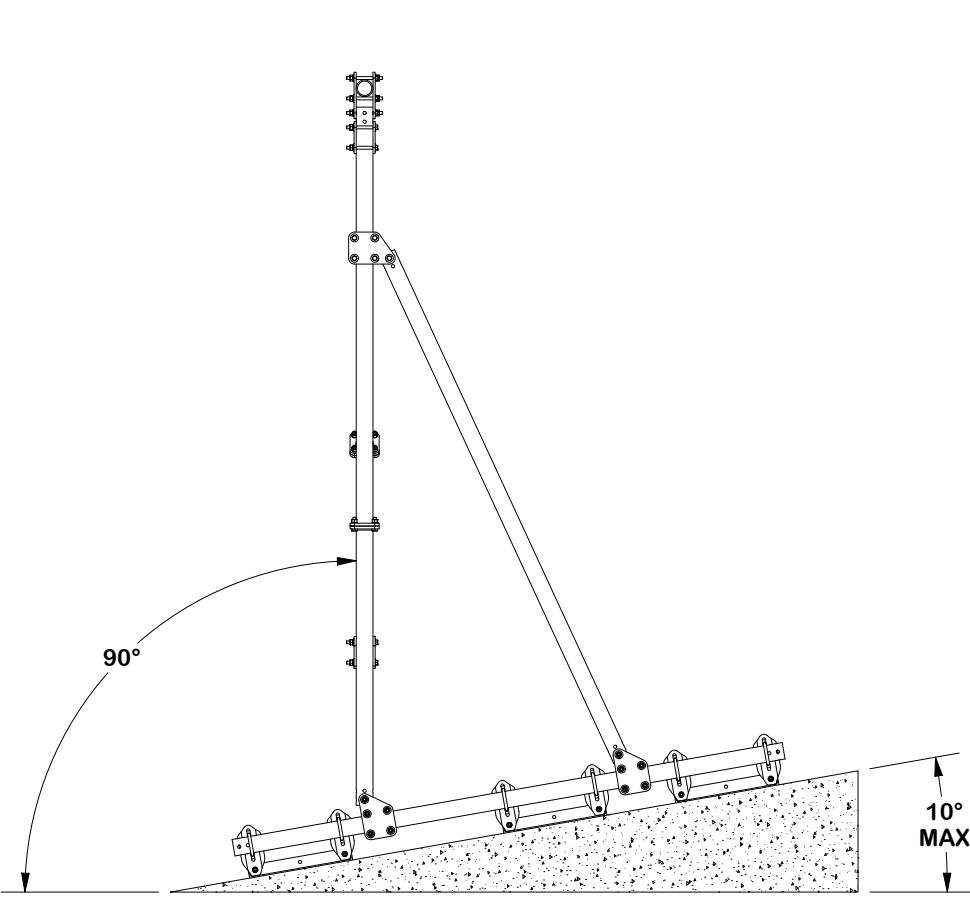

**RIGHT SIDE VIEW
FRONT SLOPE**

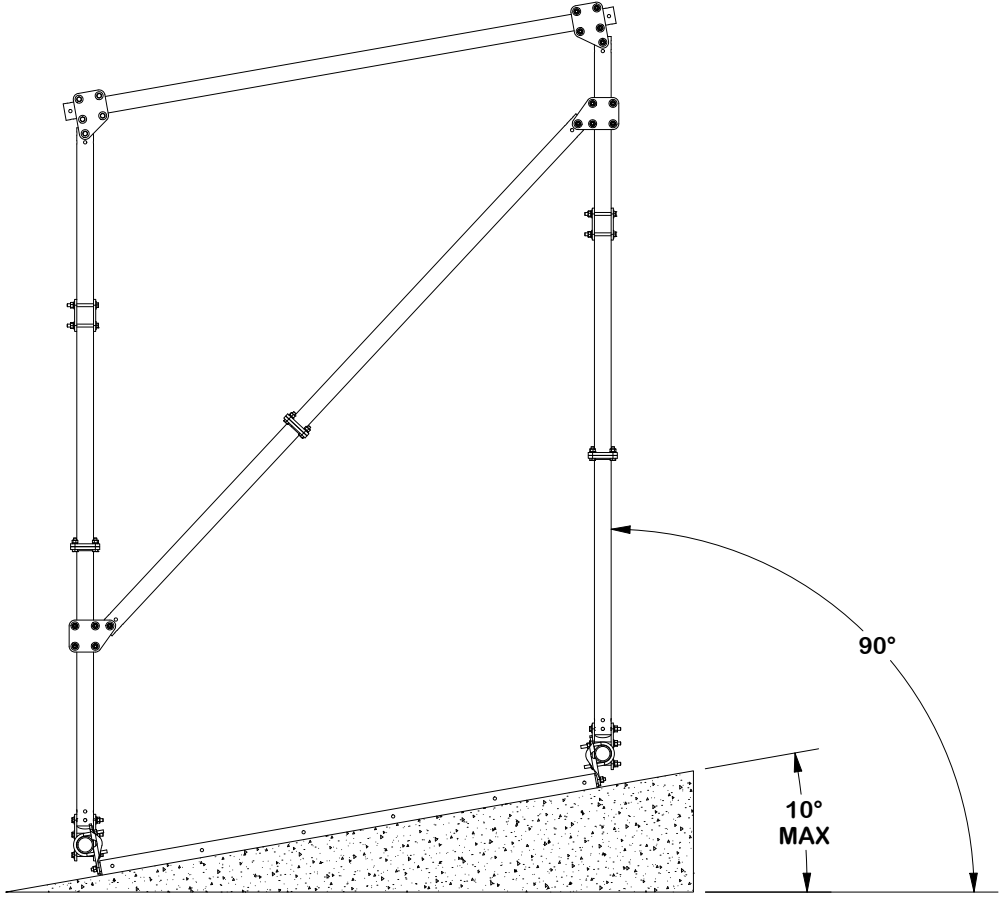

**FRONT VIEW
SIDE SLOPE**

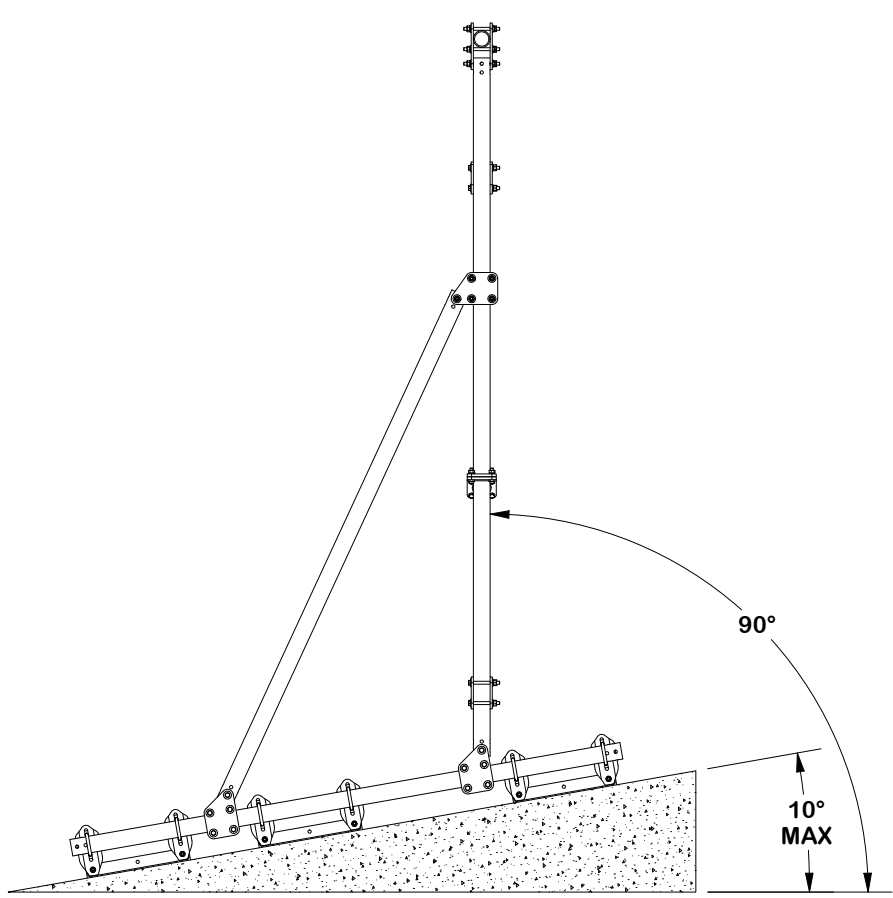

**LEFT SIDE VIEW
BACK SLOPE**

TOLERANCE NOTES

TOLERANCES ON DIMENSIONS, UNLESS OTHERWISE NOTED ARE:
 SAWED, SHEARED AND GAS CUT EDGES ($\pm 0.030"$)
 DRILLED AND GAS CUT HOLES ($\pm 0.030"$) - NO CONING OF HOLES
 LASER CUT EDGES AND HOLES ($\pm 0.010"$) - NO CONING OF HOLES
 BENDS AND ANGLES ARE $\pm 1/2$ DEGREE
 ALL OTHER MACHINING ($\pm 0.030"$)
 ALL OTHER ASSEMBLY ($\pm 0.060"$)

PATENT INFORMATION: WWW.SITEPRO1.COM/PATENTS

PROPRIETARY NOTE:
 THE DATA AND TECHNIQUES CONTAINED IN THIS DRAWING ARE PROPRIETARY INFORMATION OF VALMONT INDUSTRIES AND CONSIDERED A TRADE SECRET. ANY USE OR DISCLOSURE WITHOUT THE CONSENT OF VALMONT INDUSTRIES IS STRICTLY PROHIBITED.

DESCRIPTION
CSRT SERIES™ 2 PIPE SLOPE MOUNT
8' FACE X 10' MAST X 8' DEPTH
W/ RRU RACK

CPD NO. SP1	DRAWN BY SDR 10/8/2025	ENG. APPROVAL 11/11/2025
CLASS 87	SUB 02	DRAWING USAGE CUSTOMER
CHECKED BY ADB 11/11/2025		



Engineering Support Team:
 sp1engineering@valmont.com

A valmont COMPANY

PART NO. CSRT™ SLOPE REF
DWG. NO. CSRT2-8108-R

PARTS LIST						
ITEM	QTY	PART NO.	PART DESCRIPTION	LENGTH	UNIT WT.	NET WT.
1	1	X-CSRT-PCB	PIPE CONNECTION BRACKET	12 in	3.01	3.01
2	1	X-UB1300	1/2" X 3" X 5" X 2" GALV U-BOLT		0.74	0.74
3	1	G1202	1/2" x 2" HDG HEX BOLT GR5	2 in	0.18	0.18
4	2	G12FW	1/2" HDG USS FLATWASHER	3/32 in	0.03	0.07
5	3	G12LW	1/2" HDG LOCKWASHER	1/8 in	0.01	0.04
6	3	G12NUT	1/2" HDG HEAVY 2H HEX NUT	7/8 in	0.07	0.21
					TOTAL WT. #	4.25

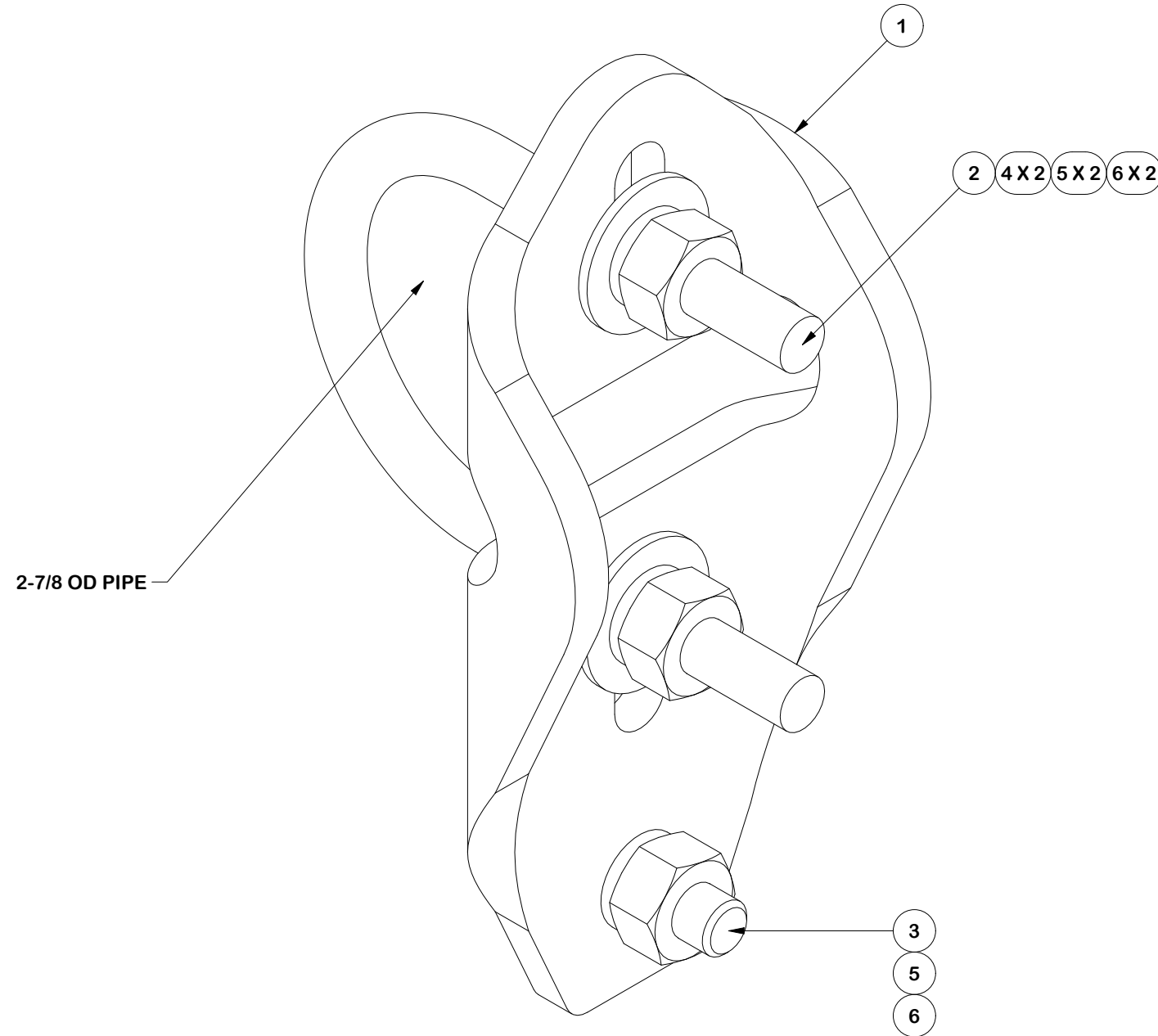

FINISH:
HOT DIP GALVANIZED.

TOLERANCE NOTES

TOLERANCES ON DIMENSIONS, UNLESS OTHERWISE NOTED ARE:
 SAWED, SHEARED AND GAS CUT EDGES ($\pm 0.030"$)
 DRILLED AND GAS CUT HOLES ($\pm 0.030"$) - NO CONING OF HOLES
 LASER CUT EDGES AND HOLES ($\pm 0.010"$) - NO CONING OF HOLES
 BENDS AND ANGLES ARE $\pm 1/2$ DEGREE
 ALL OTHER MACHINING ($\pm 0.030"$)
 ALL OTHER ASSEMBLY ($\pm 0.060"$)

PATENT INFORMATION: WWW.SITEPRO1.COM/PATENTS

PROPRIETARY NOTE:
 THE DATA AND TECHNIQUES CONTAINED IN THIS DRAWING ARE PROPRIETARY INFORMATION OF VALMONT INDUSTRIES AND CONSIDERED A TRADE SECRET. ANY USE OR DISCLOSURE WITHOUT THE CONSENT OF VALMONT INDUSTRIES IS STRICTLY PROHIBITED.

DESCRIPTION
**CSRT SERIES™ 2 PIPE SLOPE MOUNT
 8' FACE X 10' MAST X 8' DEPTH
 W/ RRU RACK**

SITE PRO 1
 Engineering Support Team:
 sp1engineering@valmont.com
 A valmont COMPANY

CPD NO. SP1	DRAWN BY SDR 10/8/2025	ENG. APPROVAL 11/11/2025
CLASS 87	SUB 02	DRAWING USAGE CUSTOMER
CHECKED BY ADB 11/11/2025		

PART NO. CSRT-PCB	PAGE 5 OF 7
DWG. NO. CSRT2-8108-R	

PARTS LIST						
ITEM	QTY	PART NO.	PART DESCRIPTION	LENGTH	UNIT WT.	NET WT.
1	2	X-CSRT-GP30	3" GUSSET PLATE	12 in	4.04	8.09
2	5	G1205	1/2" x 5" HDG HEX BOLT GR5 FULL THREAD	5 in	0.33	1.63
3	10	G12FW	1/2" HDG USS FLATWASHER	3/32 in	0.03	0.34
4	5	G12LW	1/2" HDG LOCKWASHER	1/8 in	0.01	0.07
5	5	G12NUT	1/2" HDG HEAVY 2H HEX NUT	7/8 in	0.07	0.36
					TOTAL WT. #	10.49

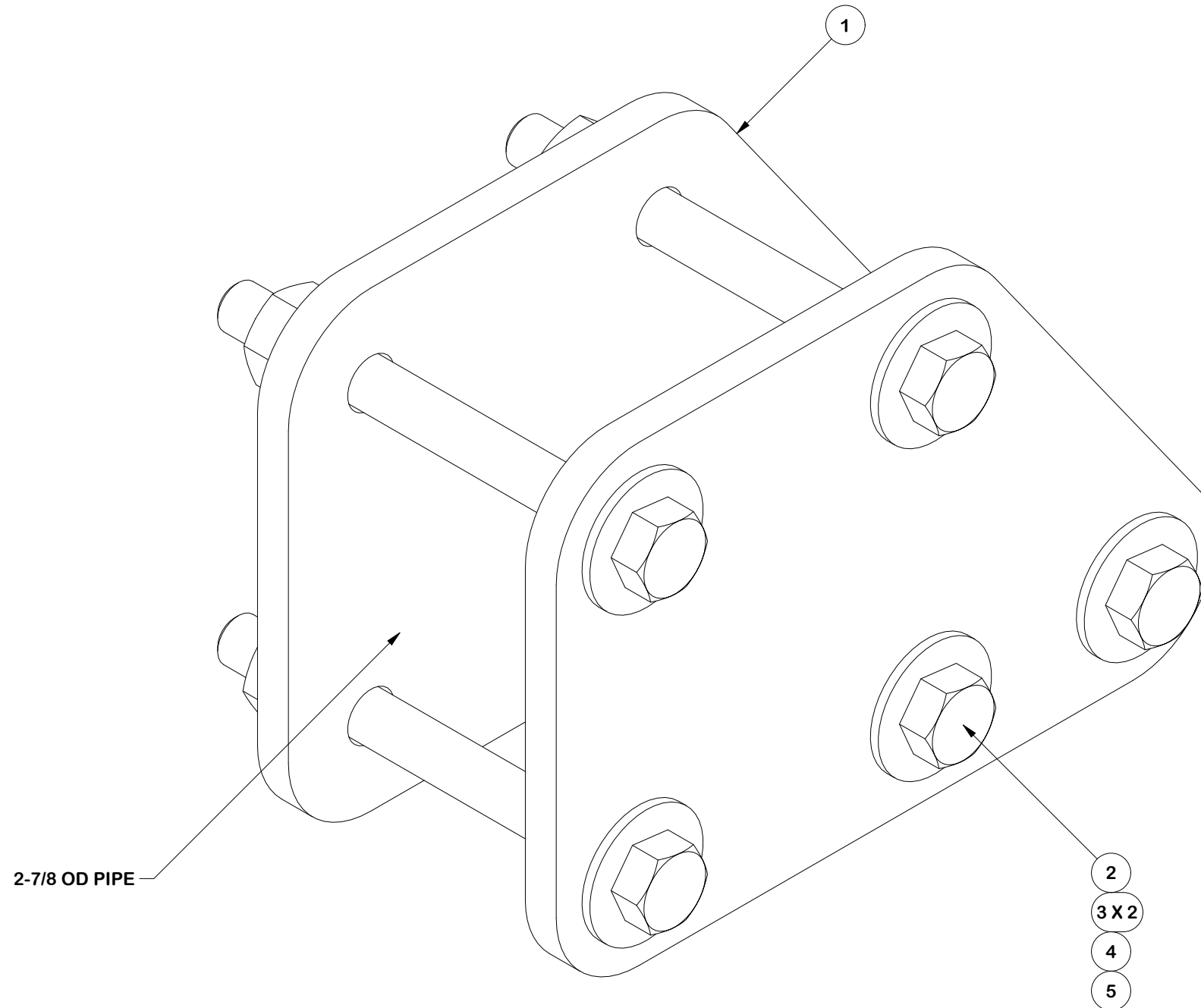

FINISH:
HOT DIP GALVANIZED.

TOLERANCE NOTES

TOLERANCES ON DIMENSIONS, UNLESS OTHERWISE NOTED ARE:
 SAWED, SHEARED AND GAS CUT EDGES ($\pm 0.030"$)
 DRILLED AND GAS CUT HOLES ($\pm 0.030"$) - NO CONING OF HOLES
 LASER CUT EDGES AND HOLES ($\pm 0.010"$) - NO CONING OF HOLES
 BENDS AND ANGLES ARE $\pm 1/2$ DEGREE
 ALL OTHER MACHINING ($\pm 0.030"$)
 ALL OTHER ASSEMBLY ($\pm 0.060"$)

PATENT INFORMATION: WWW.SITEPRO1.COM/PATENTS

PROPRIETARY NOTE:
 THE DATA AND TECHNIQUES CONTAINED IN THIS DRAWING ARE PROPRIETARY INFORMATION OF VALMONT INDUSTRIES AND CONSIDERED A TRADE SECRET. ANY USE OR DISCLOSURE WITHOUT THE CONSENT OF VALMONT INDUSTRIES IS STRICTLY PROHIBITED.

DESCRIPTION
**CSRT SERIES™ 2 PIPE SLOPE MOUNT
 8' FACE X 10' MAST X 8' DEPTH
 W/ RRU RACK**

CPD NO. SP1	DRAWN BY SDR 10/8/2025	ENG. APPROVAL 11/11/2025
CLASS 87	SUB 02	DRAWING USAGE CUSTOMER
CHECKED BY ADB 11/11/2025		



Engineering Support Team:
 sp1engineering@valmont.com

PART NO. CSRT-GP30
DWG. NO. CSRT2-8108-R

PARTS LIST						
ITEM	QTY	PART NO.	PART DESCRIPTION	LENGTH	UNIT WT.	NET WT.
1	2	X-CSRT-3048FW	CSRT FLANGE PIPE WELDMENT 2-7/8" X 48"		26.85	53.69
2	4	UNT10	UNISTRUT	120 in	20.38	81.52
3	8	UNICAP	UNISTRUT END CAP		0.03	0.26
4	4	X-UB1300	1/2 X 3" X 5" X 2" U-BOLT	5 in	0.74	2.95
5	8	G12LW	1/2" HDG LOCKWASHER	1/8 in	0.01	0.11
6	8	G12NUT	1/2" HDG HEAVY 2H HEX NUT	7/8 in	0.07	0.57
7	8	G38R-8	3/8" X 8" THREADED ROD (HDG.)		0.25	2.01
8	16	SQW38	3/8" SQUARE WASHER	2 in	0.29	4.63
9	16	G38LW	3/8" HDG LOCKWASHER		0.01	0.11
10	16	G38NUT	3/8" HDG HEAVY 2H HEX NUT		0.03	0.54
					TOTAL WT. #	149.38

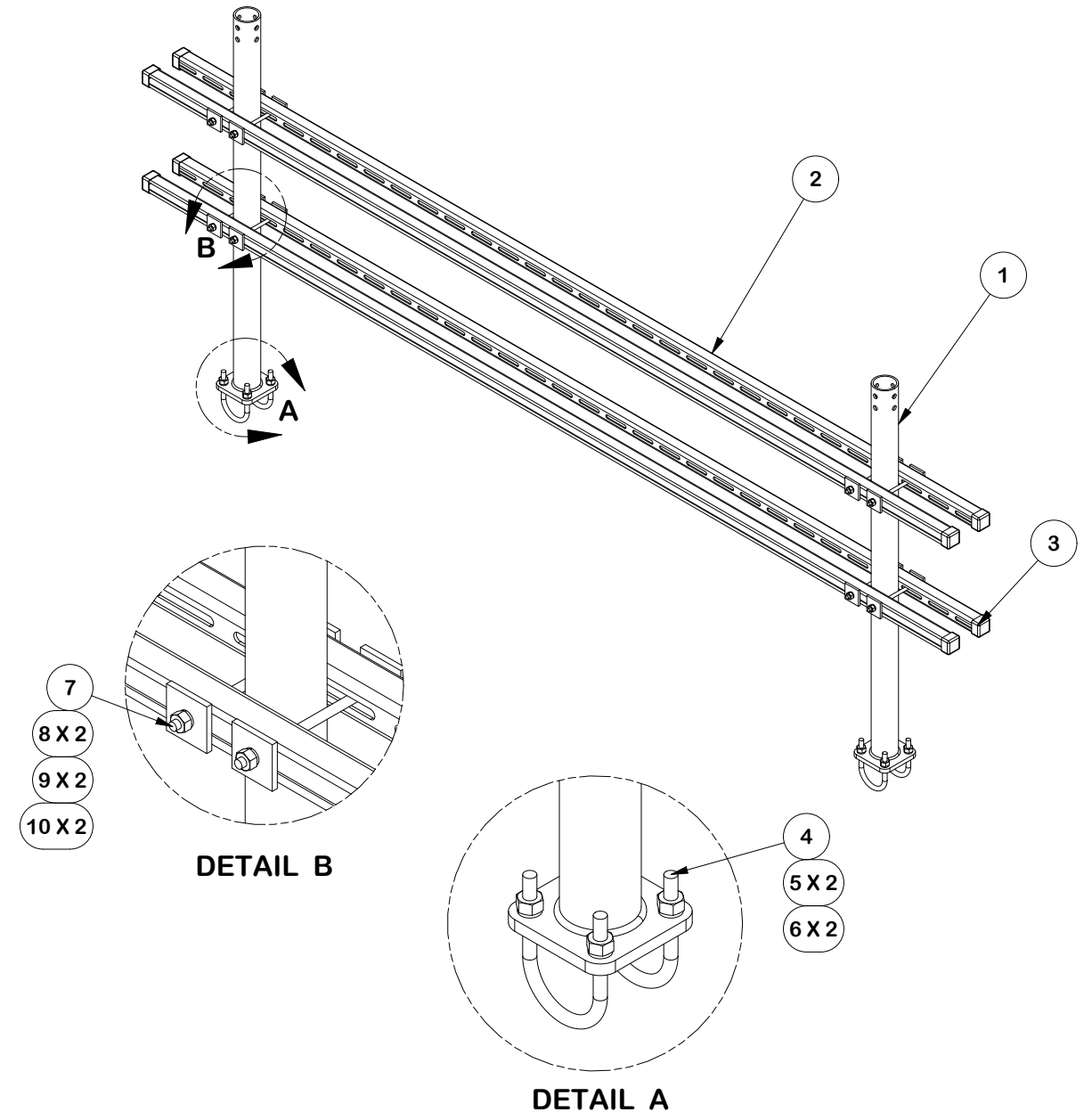
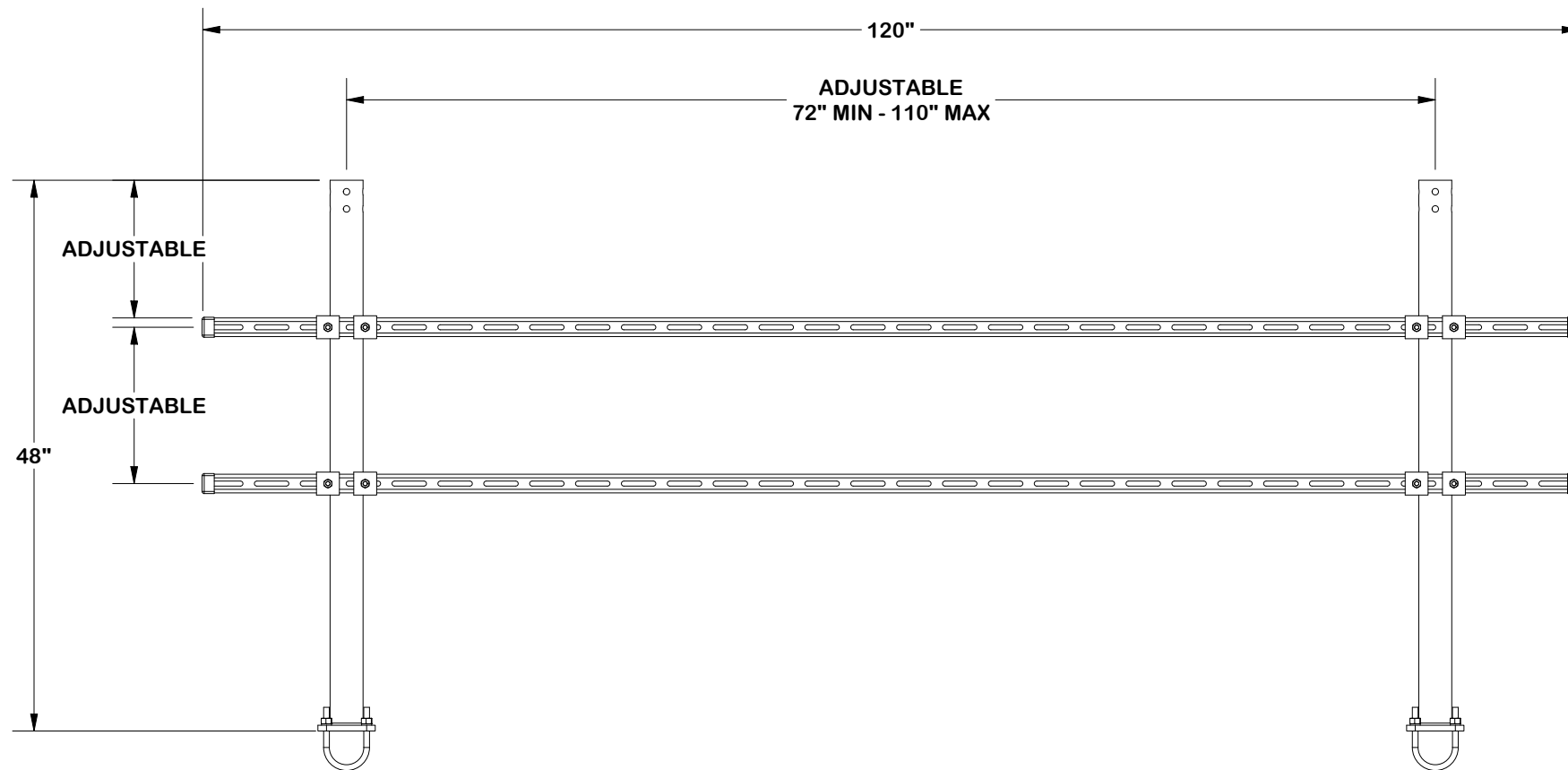
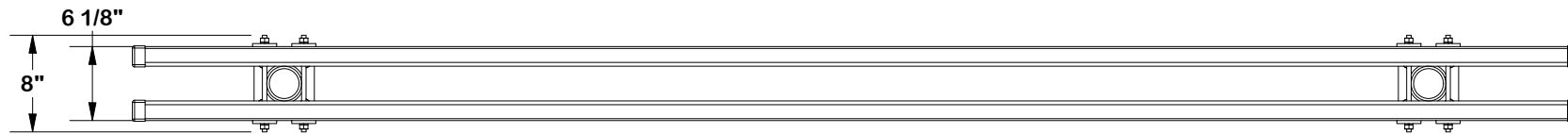

FINISH:
HOT DIP GALVANIZED.

TOLERANCE NOTES

TOLERANCES ON DIMENSIONS, UNLESS OTHERWISE NOTED ARE:
 SAWED, SHEARED AND GAS CUT EDGES ($\pm 0.030"$)
 DRILLED AND GAS CUT HOLES ($\pm 0.030"$) - NO CONING OF HOLES
 LASER CUT EDGES AND HOLES ($\pm 0.010"$) - NO CONING OF HOLES
 BENDS AND ANGLES ARE $\pm 1/2$ DEGREE
 ALL OTHER MACHINING ($\pm 0.030"$)
 ALL OTHER ASSEMBLY ($\pm 0.060"$)

PATENT INFORMATION: WWW.SITEPRO1.COM/PATENTS

PROPRIETARY NOTE:
 THE DATA AND TECHNIQUES CONTAINED IN THIS DRAWING ARE PROPRIETARY INFORMATION OF VALMONT INDUSTRIES AND CONSIDERED A TRADE SECRET. ANY USE OR DISCLOSURE WITHOUT THE CONSENT OF VALMONT INDUSTRIES IS STRICTLY PROHIBITED.

DESCRIPTION
**CSRT SERIES™ 2 PIPE SLOPE MOUNT
 8' FACE X 10' MAST X 8' DEPTH
 W/ RRU RACK**



Engineering
 Support Team:
 sp1engineering@valmont.com

A valmont COMPANY

CPD NO. SP1	DRAWN BY SDR 10/8/2025	ENG. APPROVAL 11/11/2025
CLASS 87	SUB 02	DRAWING USAGE CUSTOMER
		CHECKED BY ADB 11/11/2025

PART NO. CSRT-RRU2-410
DWG. NO. CSRT2-8108-R